

FROZEN

FOODS

ICE

CREAM



IGLOO is the perfect vending machine for ice cream and frozen foods



IGLOO

is the perfect vending machine for ice cream and frozen foods



IGLOO, the new Adimac vending machine, can host frozen products thanks to the internal **temperature of -25 C.**

The combined dispensing system with conveyor belts and spirals offers unprecedented configuration flexibility. Ideal for delivery products and packaging of various shapes and sizes.

- **GASTRONOMY**
- **PASTRY**
- **ICE CREAM**
- **MEAT**
- **FROZEN**



Hybrid configuration with spirals or conveyor belts trays

Spirals, conveyor belts or both? Several dispensing modes allow configuring Igloo by inserting up to a maximum of 80 different products: single, packaged or artisanal ice cream, pizzas, fresh meals, meat, fish, vegetables and prepared food.

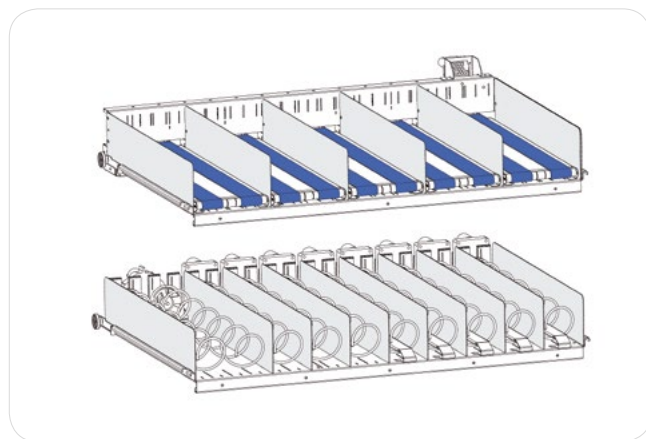

Automatic door in a raised position and integrated lift

Products slide gently on the latest generation lift to avoid any kind of impact and damage. The withdrawal compartment in raised position allows you to take the product comfortably without bending.

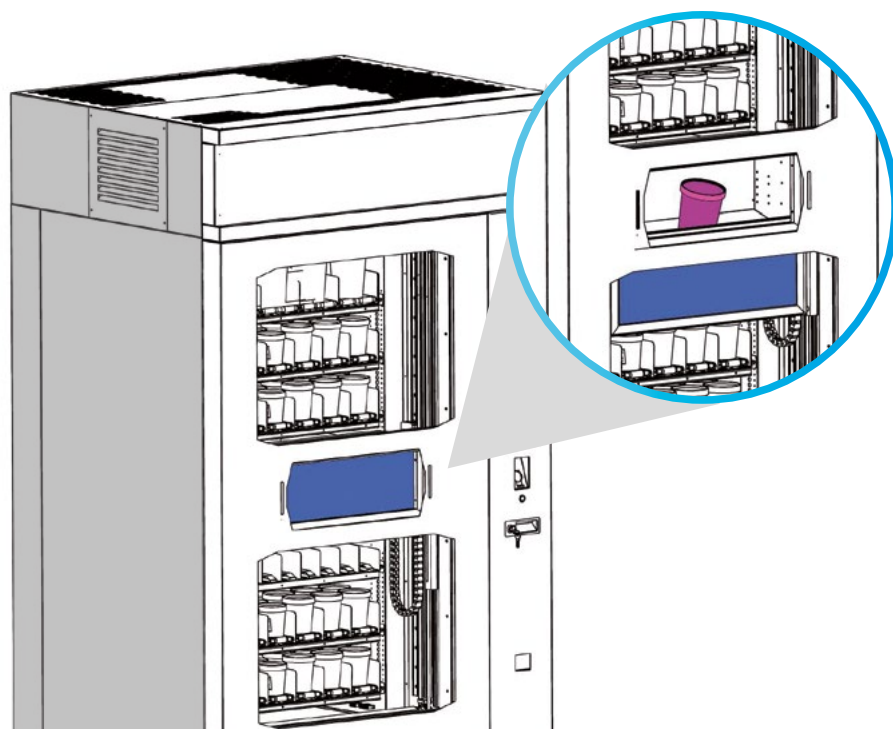



Check in real time and from remote with **AD - Cloud**

Simple and innovative, the AD Cloud system optimizes all control, support and update operations on machines. All networked devices can be monitored from anywhere and from any device.

- Real-time stock control and under-stock management.
- Monitoring of transactions.
- Export of all system data (daily, weekly and monthly reports).
- Configure and customize your dashboard.
- Sharing data with your employees.
- Multi-user management.



Touch screen with display 10 or 21.5 inches

The touch screen offers more interactivity by user and easy and intuitive product selection.



Warehouse drawer for frozen products

Large space to store products for total volume of 65 litres.



Settable temperature **up to a -25°C**

The refrigeration system, equipped with multiple sensors, can reach -25 °C to ensure the correct storage of frozen foods until their delivery.

CHARACTERISTICS

Height of delivery area	90,7 cm
Maximum number of shelves	8
Lanes per shelf	10
Maximum active power	1220 W
Power supply	230 V / 50 Hz
Consuming	700 - 1400 W
Weight	500 kg

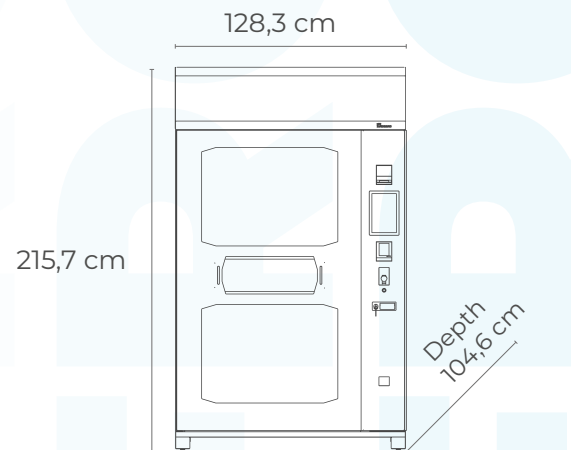



Adimac – Nuova Inox Srl brand

Via dei Pini, 50 - 36016 Thiene (VI) - Italy

T. +39 0445 361034

info@adimac.it

www.adimac.it

